

FEATURES

- InGaP HBT Technology
- +25 dBm Linear Output Power
- 31 dB Gain
- 2.5 % EVM QPSK 1/2 CTC, 16 QAM OFDMA Modulation
- High Efficiency
- Integrated Voltage Regulator (eliminates need for external reference voltage)
- Integrated Output Power Detector
- Integrated Step Attenuator
- Low Leakage Current in Shutdown Mode: 20 μ A
- Optimized for a 50 Ω System
- Low Profile Miniature Surface Mount Package
- RoHS Compliant Package

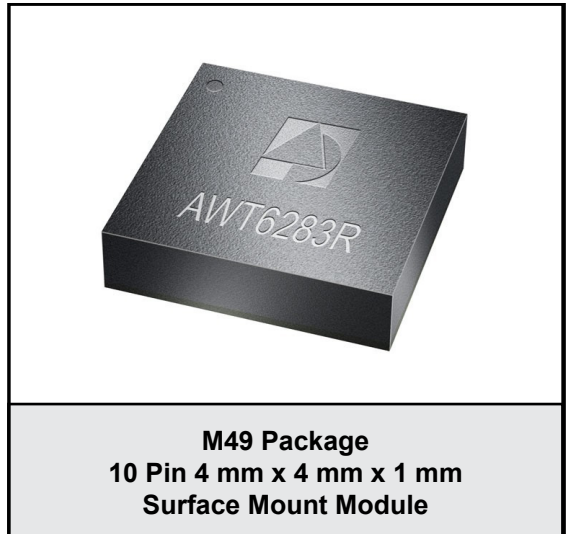

APPLICATIONS

- Mobile WiMAX Data Cards and Terminals that Support the IEEE 802.16e (2005) Standard

PRODUCT DESCRIPTION

The AWT6283R meets the stringent linearity and output power requirements of the Mobile WiMAX high speed data system. The device is manufactured on an advanced InGaP HBT MMIC technology offering state-of-the-art reliability, temperature stability, and ruggedness. An integrated step attenuator enables

gain control, and an integrated voltage regulator eliminates the need for an external reference voltage. The self-contained 4 mm x 4 mm x 1 mm surface mount package incorporates matching networks optimized for output power, efficiency, and linearity in a 50 Ω system.

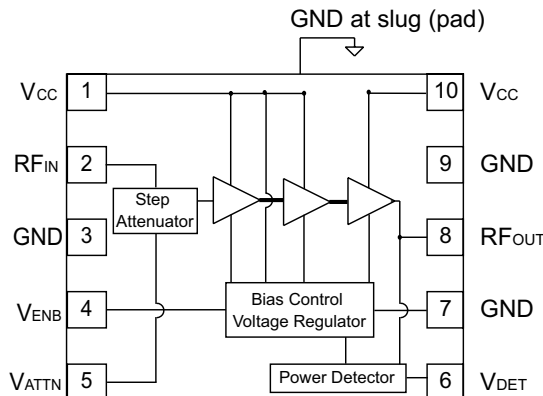

Figure 1: Block Diagram

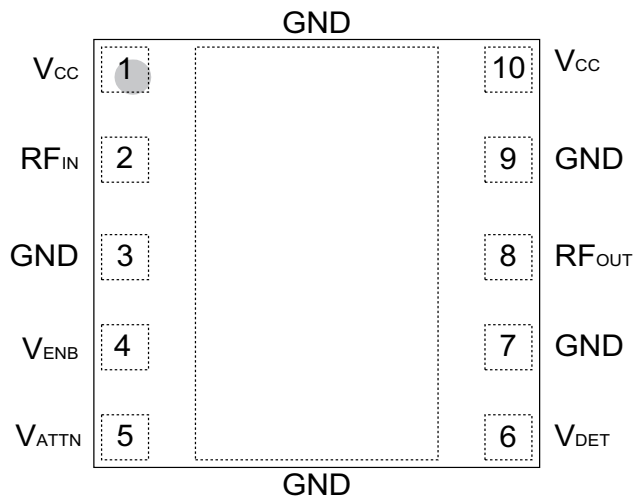

Figure 2: Pinout (X-ray Top View)

Table 1: Pin Description

PIN	NAME	DESCRIPTION
1	V _{CC}	Supply Voltage
2	RF _{IN}	RF Input
3	GND	Ground
4	V _{ENB}	PA Enable Voltage
5	V _{ATTN}	Attenuator Control Voltage
6	V _{DET}	Detector Output Voltage
7	GND	Ground
8	RF _{OUT}	RF Output
9	GND	Ground
10	V _{CC}	Supply Voltage

ELECTRICAL CHARACTERISTICS

Table 2: Absolute Minimum and Maximum Ratings

PARAMETER	MIN	MAX	UNIT
Supply Voltage (V_{CC})	0	+5	V
Enable Voltage (V_{ENB})	0	+3.2	V
Attenuator Control Voltage (V_{ATTN})	0	+3.7	V
RF Input Power (P_{IN})	-	0	dBm
ESD Rating: Human Body Model ⁽¹⁾ Charged Device Model ⁽²⁾	250 1000	- -	V
MSL Rating ⁽³⁾	3	-	-
Storage Temperature (T_{STG})	-40	+150	°C

Stresses in excess of the absolute ratings may cause permanent damage. Functional operation is not implied under these conditions. Exposure to absolute ratings for extended periods of time may adversely affect reliability.

Notes:

(1) JEDEC Class 1A

(2) JEDEC Class IV

(3) 260 °C Peak Reflow

Table 3: Operating Ranges

PARAMETER	MIN	TYP	MAX	UNIT	COMMENTS
Operating Frequency (f)	3300	-	3800	MHz	
Supply Voltage (V_{CC})	+3.0	+3.3	+4.2	V	
Enable Voltage (V_{ENB})	+2.7 0	+2.9 -	+3.1 +0.5	V	PA "on" PA "shut down"
Attenuator Control Voltage (V_{ATTN}) Logic High Logic Low	+2.3 0	- -	+3.7 +0.7	V	Attenuator Enabled Attenuator Disabled
RF Output Power (P_{OUT})	-	+25	-	dBm	
Case Temperature (T_C)	-40	-	+85	°C	

The device may be operated safely over these conditions; however, parametric performance is guaranteed only over the conditions defined in the electrical specifications.

Table 4: Electrical Specifications - QPSK 1/2 CTC, Zone = AMC 4:2
 (T_C = +25 °C, V_{CC} = +3.3 V, V_{ENB} = +2.9 V, 50 Ω system)

PARAMETER	MIN	TYP	MAX	UNIT	COMMENTS
Gain ⁽²⁾	28.5	31	37.5	dB	
Attenuation	17	20	25	dB	V _{ATTN} = 2.5 V
SEM ^{(1), (2)} @ Offset A @ Offset B @ Offset C @ Offset D	-	-	-51.37 -40.5 -50.5 -50.5	dBc	10 MHz Channel bandwidth WiMAX Forum Band Class 5C MRRT
Power-Added Efficiency ^{(1), (2)}	19.2	21.8	-	%	
Thermal Resistance (R _{JC})	-	24	-	°C/W	
Supply Current (I _{CC}) ⁽²⁾	-	440	500	mA	
EVM ⁽²⁾	-	2.5	4	%	
Power Detector Output @ 25 dBm	-	1.3	-	V	RL (Load Resistor) = 100K Ω
Quiescent Current (I _Q)	90	145	170	mA	
PA Enable Current	0.6	3.5	5.0	mA	through V _{ENB} pin
Leakage Current	-	20	100	μA	V _{CC} = +3.3 V, V _{ENB} = 0 V
Harmonics ⁽²⁾ 2fo 3fo, 4fo	-	-42 -58	-	dBc	
Input Impedance	-	2:1	-	VSWR	
Spurious Output Level (all spurious outputs)	-	-	-60	dBc	P _{OUT} < +25 dBm In-band load VSWR < 5:1 Out-of-band load VSWR < 10:1 Applies over all voltage and temperature operating ranges
Load mismatch stress with no permanent degradation or failure	8:1	-	-	VSWR	V _{CC} = +4 V, P _{IN} = 0 dBm Applies over full operating temperature range

Notes:

(1) Spectrum Mask and Efficiency measured at 3600 MHz.

(2) P_{OUT} = +25 dBm

Table 5: Electrical Specifications - 16 QAM PUSC Zone
(T_C = +25 °C, V_{CC} = +3.3 V, V_{ENB} = +2.9 V, 50 Ω system)

PARAMETER	MIN	TYP	MAX	UNIT	COMMENTS
Gain ⁽²⁾	-	31	-	dB	
Attenuation	-	20	-	dB	V _{ATTN} = 2.5 V
SEM ^{(1), (2)} @ OFFSET A @ OFFSET B @ OFFSET C @ OFFSET D	- - - -	- - - -	-51.37 -40.5 -50.5 -50.5	dBc	10 MHz channel bandwidth WiMAX Forum Band Class 5C MRRT
Power-Added Efficiency ^{(1), (2)}	-	21.8	-	%	
Thermal Resistance (R _{JC})	-	24	-	°C/W	
Supply Current (I _{CC}) ⁽²⁾	-	440	-	mA	
EVM ⁽²⁾	-	2.5	-	%	
Power Detector Output @ 25 dBm	-	1.3	-	V	RL (Load Resistor) = 100K Ω
Quiescent Current (I _Q)	-	145	-	mA	
PA Enable Current	-	3.5	-	mA	through V _{ENB} pin
Leakage Current	-	20	-	μA	V _{CC} = +3.3 V, V _{ENB} = 0 V
Harmonics ⁽²⁾ 2fo 3fo,4fo	- - -	-42 -58	- -	dBc	
Input Impedance	-	2:1	-	VSWR	
Spurious Output Level (all spurious outputs)	-	-	-60	dBc	P _{OUT} < +25 dBm In-band load VSWR < 5:1 Out-of-band load VSWR < 10:1 Applies over all voltage and temperature operating ranges
Load mismatch stress with no permanent degradation or failure	8:1	-	-	VSWR	V _{CC} = +4 V, P _{IN} = 0 dBm Applies over full operating temperature range

Notes:

(1) Spectrum Mask and Efficiency measured at 3600 MHz.

(2) P_{OUT} = +25 dBm

APPLICATION INFORMATION

To ensure proper performance, refer to all related Application Notes on the ANADIGICS web site: <http://www.anadigics.com>

Shutdown Mode

The power amplifier may be placed in a shutdown mode by applying logic low levels (see Operating Ranges table) to the V_{ENB} voltage.

Table 6: Bias Control

APPLICATION	P _{OUT} LEVELS	BIAS MODE	V _{ENB}	V _{CC}
WiMAX - high power	All	High	+2.9 V	+3.3
Shutdown	-	Shutdown	0 V	-

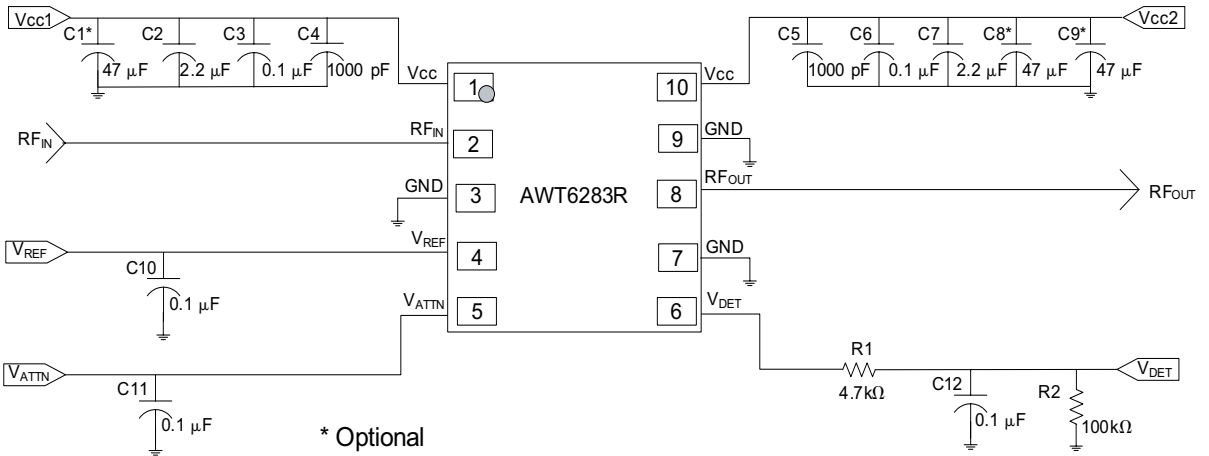
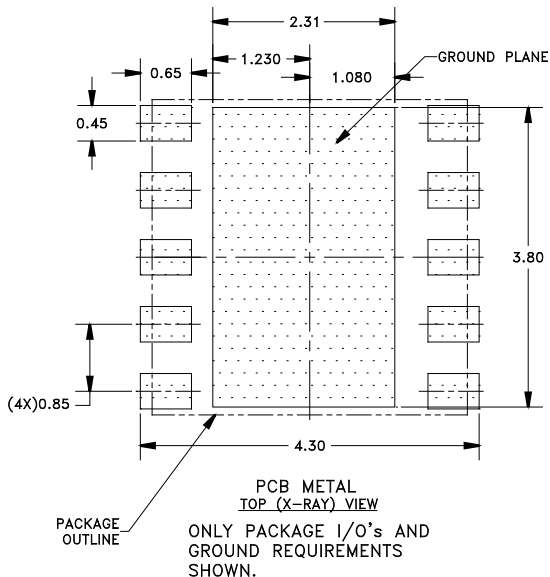

Figure 3: Application Circuit Schematic



NOTES:

- (1) UNLESS SPECIFIED DIMENSIONS ARE SYMMETRICAL ABOUT CENTER LINES SHOWN.
- (2) DIMENSIONS IN MILLIMETERS.

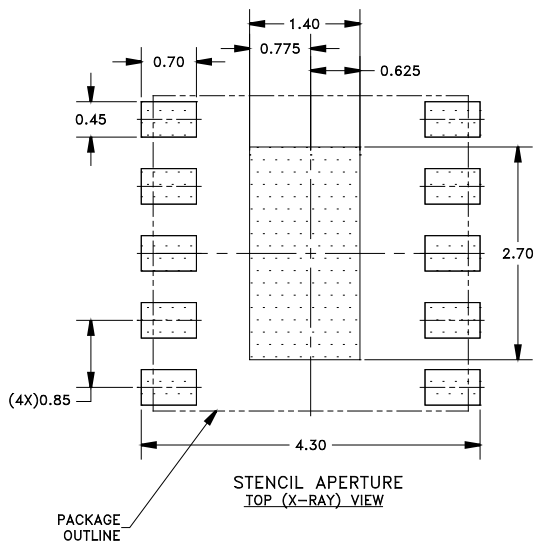
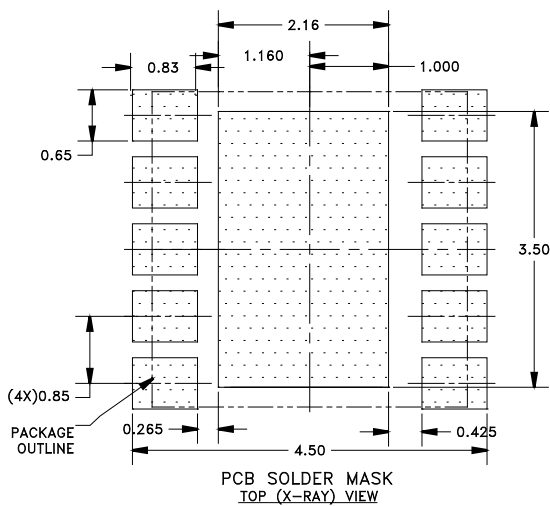
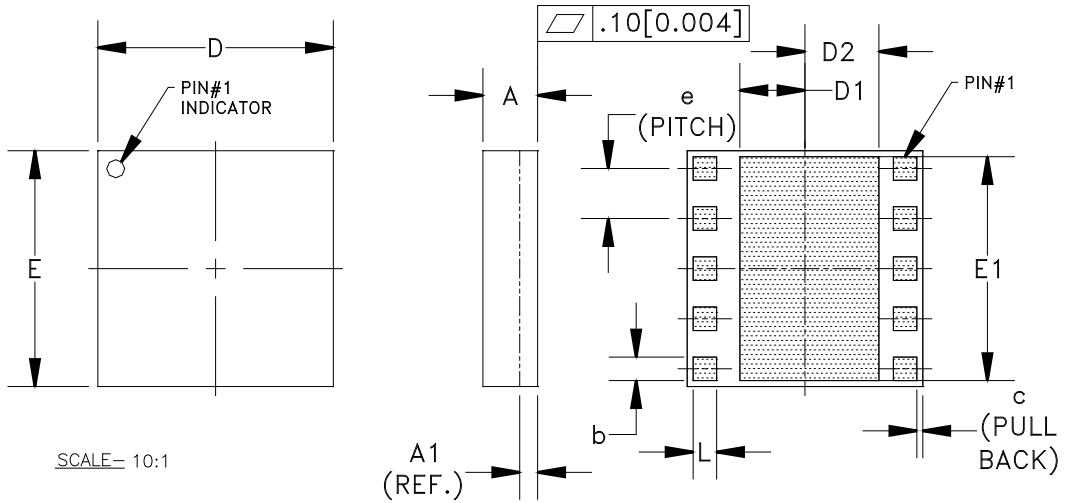

Figure 4: PCB Footprint

PACKAGE OUTLINE



SCALE= 10:1

S _M No.	MILLIMETERS			INCHES			NOTE
	MIN.	NOM.	MAX.	MIN.	NOM.	MAX.	
A	0.85	0.93	1.01	0.033	0.037	0.040	-
A1	0.27 (REF.)			0.011(REF.)			-
b	0.35	0.40	0.45	0.014	0.016	0.018	3
c	-	0.10	-	-	0.004	-	-
D	3.88	4.00	4.12	0.152	0.157	0.162	-
D1	1.055	1.105	1.155	0.047	0.044	0.045	-
D2	1.205	1.255	1.305	0.049	0.049	0.051	-
E	3.88	4.00	4.12	0.152	0.157	0.162	-
E1	3.75	3.8	3.85	0.148	0.150	0.152	-
e	0.85			0.033			3
L	0.35	0.40	0.45	0.014	0.016	0.018	3

NOTES:

1. CONTROLLING DIMENSIONS: MILLIMETERS
2. UNLESS SPECIFIED TOLERANCE=±0.076[0.003].
3. PADS (INCLUDING CENTER) SHOWN UNIFORM SIZE FOR REFERENCE ONLY. ACTUAL PAD SIZE AND LOCATION WILL VARY WITHIN MIN. AND MAX. DIMENSIONS ACCORDING TO SPECIFIC LAMINATE DESIGN.

Figure 5: M49 Package Outline - 10 Pin 4 mm x 4 mm x 1 mm Surface Mount Module

TOP BRAND

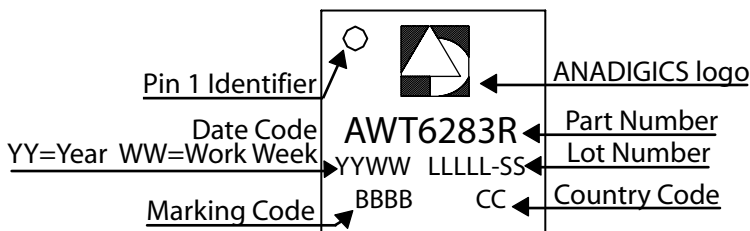
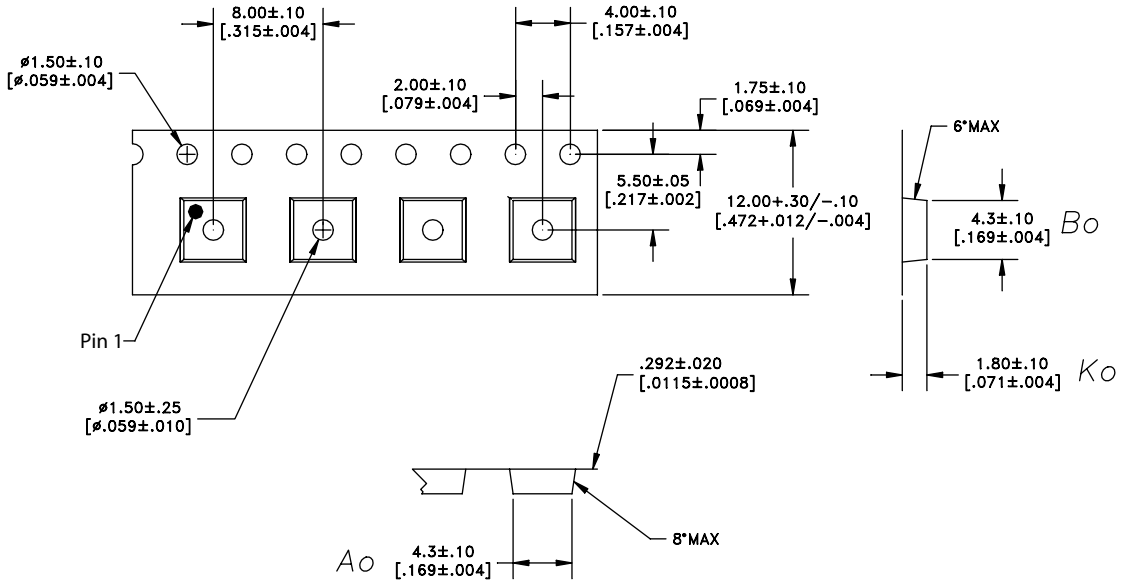

Figure 6: Branding Specification

COMPONENT PACKAGING



DIMENSIONS ARE IN MILLIMETERS [INCHES]
STANDARD TOLERANCES

Figure 7: Tape & Reel Packaging

Table 8: Tape & Reel Dimensions

PACKAGE TYPE	TAPE WIDTH	POCKET PITCH	REEL CAPACITY	MAX REEL DIA
4 mm x 4 mm x 1 mm	12 mm	8 mm	2500	13"

ORDERING INFORMATION

ORDER NUMBER	TEMPERATURE RANGE	PACKAGE DESCRIPTION	COMPONENT PACKAGING
AWT6283RM49P8	-40 °C to +85 °C	RoHS-compliant 10 Pin 4 mm x 4 mm x 1 mm Surface Mount Module	Tape and Reel, 2500 pieces per Reel



ANADIGICS

141 Mount Bethel Road
Warren, New Jersey 07059, U.S.A.
Tel: +1 (908) 668-5000
Fax: +1 (908) 668-5132

URL: <http://www.anadigics.com>

IMPORTANT NOTICE

ANADIGICS, Inc. reserves the right to make changes to its products or to discontinue any product at any time without notice. The product specifications contained in Advanced Product Information sheets and Preliminary Data Sheets are subject to change prior to a product's formal introduction. Information in Data Sheets have been carefully checked and are assumed to be reliable; however, ANADIGICS assumes no responsibilities for inaccuracies. ANADIGICS strongly urges customers to verify that the information they are using is current before placing orders.

WARNING

ANADIGICS products are not intended for use in life support appliances, devices or systems. Use of an ANADIGICS product in any such application without written consent is prohibited.